

# MIDIO1 + MIDIO4

# UHT – MIDI Encoder ‚MIDIO4‘

- For the connection of up to 4 UHT – organ keyboards / pedal boards
- Inputs for UHT - manuals with single contacts (ON/OFF) and/or double contacts (velocity)
- Features: 16 MIDI-channels, 4 velocity curves, dynamic ON/OFF, when dynamic is OFF, the upper or lower contact can be used

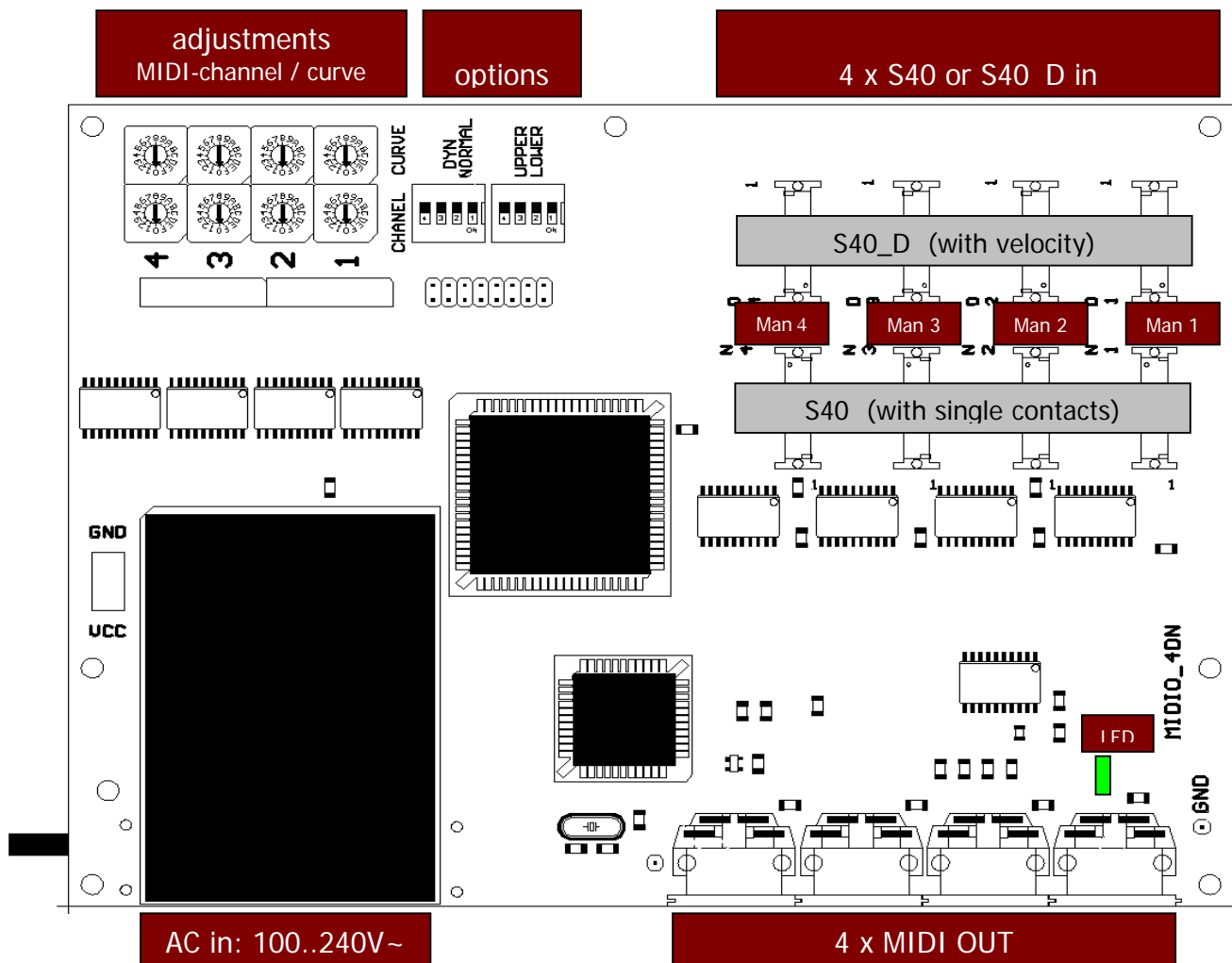

## safety guideline:

The AC - adapter warms up.  
Please avoid heat build-up!

1. The cables coming out of the manuals have to be connected to the sockets ,Man1'...'Man4'
  - Always start with **Man 1!**
  - snap the plug **carefully!**
  - red core in direction 1

**Important!**

**Please do not connect manuals with a single contact system (N) to the sockets for manuals with double contact system (D). If you are not shure, please contact us!**

2. Connect the MIDI-cabel to one of the 4 sockets
3. Connect the main cabel...
4. Start with switch 1 to adjust the MIDI channel
  - Pos."0"= channel 1.....Pos."F"= channel 16
5. Adjust the velocity curves (only for keyboards with double contact system)
  - MIDIO\_4 has 4 velocity curves > switch to Pos "1, 2, 3 or 4"

- Unused manuals (sockets) have to be switched to Pos."0"!! These channels are OFF !

- The velocity can also be switched off. Automatically the upper contact will be scanned
- With the UPPER/LOWER-switch you can choose between the upper and the lower contact

6. the green LED - lamp turns on with every key contact



## UHT – MIDI Encoder ‚MIDIO1‘

- MIDIO\_1 is specially designed for the connection of 1 UHT – organ keyboard / pedal board
- Inputs for UHT - manuals with single contacts (ON/OFF) and/or double contacts (velocity)
- features: 16 MIDI-channels, 3 velocity curves, velocity OFF (= upper contact), Change (= lower contact)

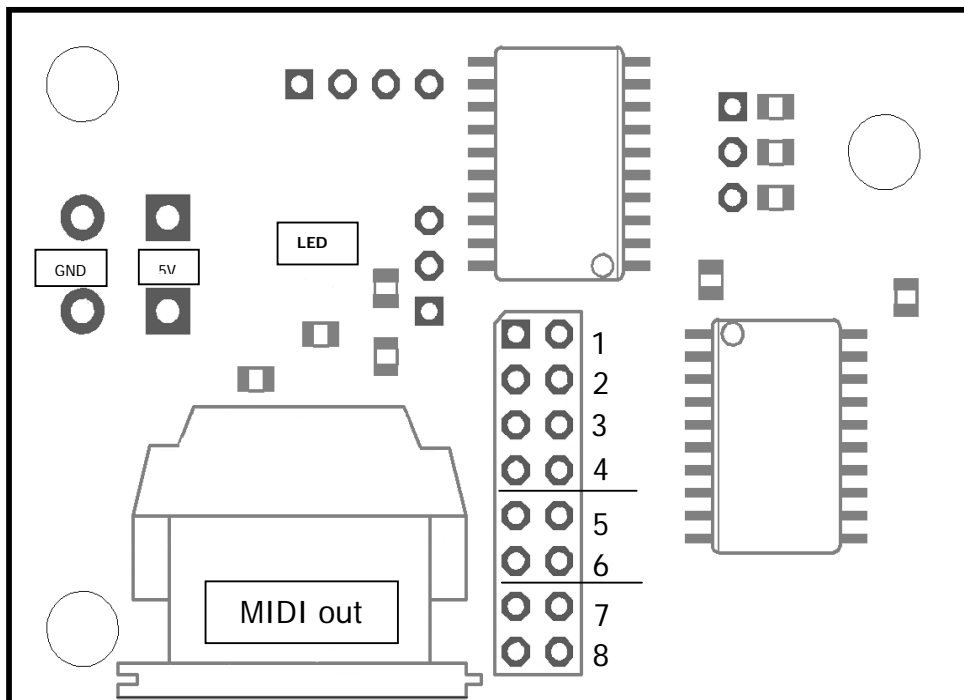
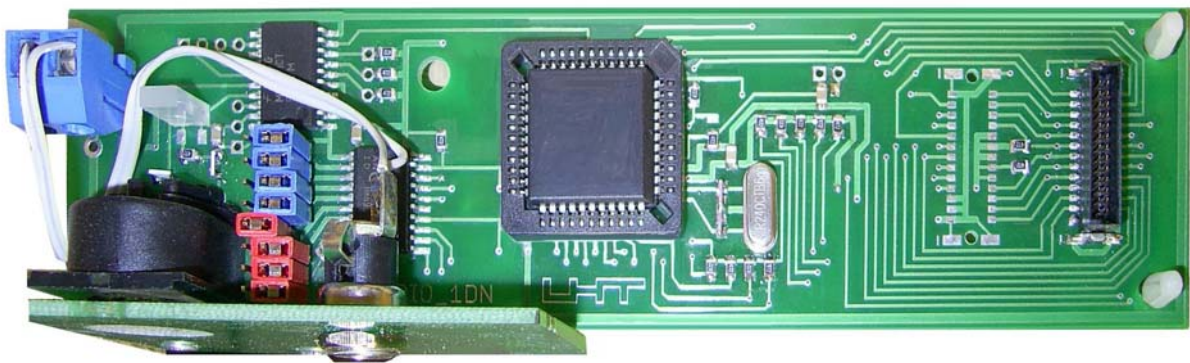



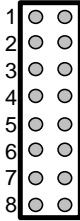
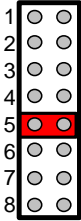
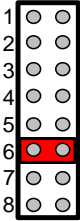
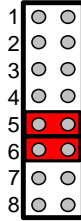

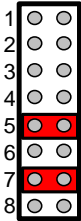
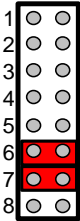
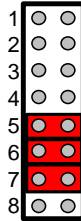
# UHT - MIDI01 - jumper set table

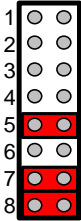
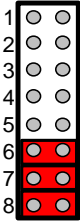
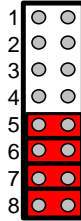
 <p>all functions MIDI_1 = off</p>	 <p>channel 1 MIDI_1 = on velocity 1 dynamic = on</p>	 <p>channel 1 MIDI_1 = on velocity 2 dynamic = on</p>	 <p>channel 1 MIDI_1 = on velocity 3 dynamic = on</p>
-------------------------------------------------------------------------------------------------------------------------	----------------------------------------------------------------------------------------------------------------------------------------------------	----------------------------------------------------------------------------------------------------------------------------------------------------	------------------------------------------------------------------------------------------------------------------------------------------------------

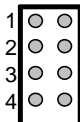
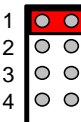
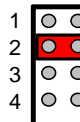
<p>SET DYNAMIC OFF</p>	 <p>channel 1 MIDI_1 = on dynamic = off contact upper</p>	 <p>channel 1 MIDI_1 = on dynamic = off contact upper</p>	 <p>channel 1 MIDI_1 = on dynamic = off contact upper</p>
------------------------	--------------------------------------------------------------------------------------------------------------------------------------------------------	--------------------------------------------------------------------------------------------------------------------------------------------------------	----------------------------------------------------------------------------------------------------------------------------------------------------------

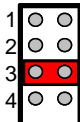
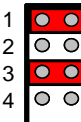
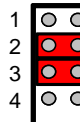
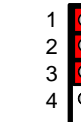
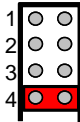
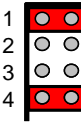
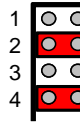
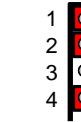
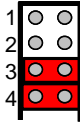
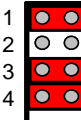
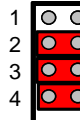
<p>SET CONTACT LOWER</p>	 <p>channel 1 MIDI_1 = on dynamic = off contact lower</p>	 <p>channel 1 MIDI_1 = on dynamic = off contact lower</p>	 <p>channel 1 MIDI_1 = on dynamic = off contact lower</p>
--------------------------	---------------------------------------------------------------------------------------------------------------------------------------------------------	---------------------------------------------------------------------------------------------------------------------------------------------------------	-----------------------------------------------------------------------------------------------------------------------------------------------------------

SET CHANNEL JUMPER			
 <p>channel 1</p>	 <p>channel 2</p>	 <p>channel 3</p>	 <p>channel 4</p>
 <p>channel 5</p>	 <p>channel 6</p>	 <p>channel 7</p>	 <p>channel 8</p>
 <p>channel 9</p>	 <p>channel 10</p>	 <p>channel 11</p>	 <p>channel 12</p>
 <p>channel 13</p>	 <p>channel 14</p>	 <p>channel 15</p>	 <p>channel 16</p>